

# TURRET ECX30

4-WHEEL 100% AC ELECTRIC 36/48 VOLT  
6000 lbs. (3000 kg)

# C300C

4-WHEEL IC-CUSHION LPG  
6000 lbs. (3000 kg)



YOUR SUPERIOR SOLUTION FOR  
**HIGH-CAPACITY  
NARROW  
AISLE STORAGE**

**CLARK**<sup>®</sup>  
**THE FORKLIFT**

# Why a Turret Truck?

To provide a cost-effective alternative to higher-priced, dedicated narrow aisle turret style trucks.

The most unique feature of the full **180° pivoting carriage design** is that the truck can pick/place a 48 inch long load in a 72 inch unguided aisle on either side of the lift truck\*. This gives the operator virtually unlimited load retrieving options and **lower cycle times**.

The CLARK turret truck can also be used outside the rack area to pick and carry loads. **Use one truck** to unload a trailer, carry the load to a narrow aisle rack area, and place it in the rack on either side. The potential cost savings makes the CLARK turret truck **the ultimate side-shifter**. (A special attachment with tilting forks is also available.)



*\*Contact CLARK for guided aisle applications. A 300 inch MFH upright will allow a load to be placed on a rack height of 268 inches. Higher heights may be possible upon request with reduced capacity. All lift heights have 3000 lbs. capacity at 12 inch carry position with forks extended. Contact factory for specific capacity information at intermediate lift heights.*

# What makes the CLARK Turret Trucks better than the competition?

■ The CLARK I-Beam style nested rails are stiffer for side-loading due to larger symmetrical sections. Additional modifications to the upright and carriage design are made so that the turret attachment is integral; this results in higher capacities and less deflection than the competition.

■ Four external side thrust carriage rollers further limit deflection.

■ Adjustable flow controls simplify set-up and reduce heat to the hydraulics systems.

■ The “standard” model is a cushion truck with 6000 lbs. nominal capacity. Since lateral stability is the determining factor, increasing to a 6500 lbs. model provides no additional capacity.

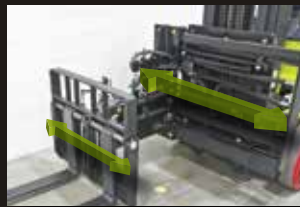

## ■ Compound & Traverse Sideshift

- Allows for greater lateral movement in the aisle, reducing truck front end width.



## ■ 180° Pivoting Action

- Operator can work either side of the aisle, regardless of truck orientation.

## Increased Flexibility = Higher Productivity

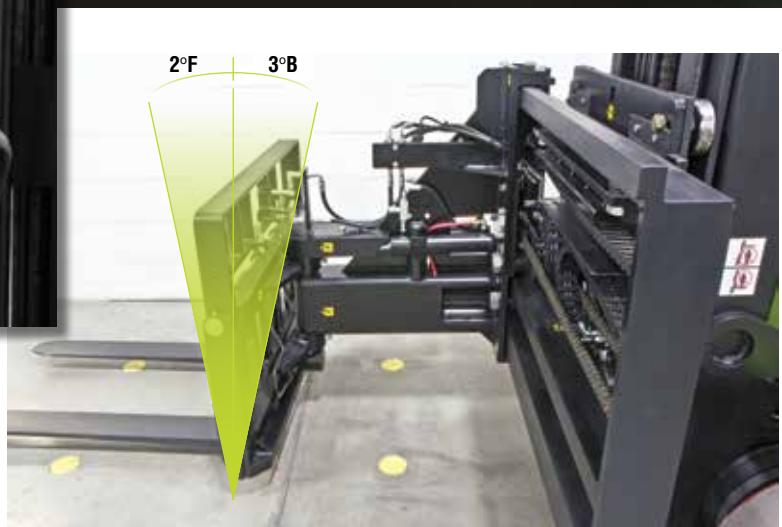

## ■ Maintenance Friendly

- The turret attachment is built with standard drive components. Fast parts availability and minimized service costs keep uptime to a maximum.

**Extremely Dependable • Highly Efficient • Easily Serviceable**

**A**t the heart of the CLARK turret trucks, the CLARK ECX30 electric & C30C internal combustion lift trucks are the ideal choice for demanding manufacturing and distribution applications. Superior ergonomic design, operator comfort & safety, and outstanding truck performance are backed by the oldest and most trusted name in lift trucks.



Recognizing the benefit of AC technology, CLARK developed the ECX with not just AC traction motors – but **ALL AC MOTORS.**

■ **Fewer Parts & Minimum Wear = Less Downtime and Cost = Higher ROI**

- Enclosed • Thermal protection
- Smart lift lock out • One motor for both steering & hydraulics.

■ **No Brushes to change or Commutator to turn... EVER.**

■ **Heavy-Duty, High Torque Drive Motor**

- Produces twice the draw bar pull of some competitors.

■ **Stall Protection**

■ **Three Forms of Regenerative Braking**

- Returning energy to the battery increases runtime.



The **operator compartment** on the ECX30 & C30C is designed to ensure the operator a comfortable ride.

■ **Grab Handles & Low Step Height**

- Allow for easy entry/exit from either side, reducing strain.

■ **Fully Adjustable Safety Seat & Steering Column**

- 20° backrest range and 6" fore/aft adjustment.
- Contoured for support.
- Allows for individual fit, increasing productivity.
- Non-cinching, retractable seat belt.
- Side safety wings.

■ **Thick Molded Floor Mat**

- Reduces vibration & noise level to improve comfort.

■ **Large Operator Compartment**

- Accommodates the 95% percentile person in height range.

**Lowering Operator Fatigue = Extended Work Rates = Increased Yield**

# Turret Upright Dimensions (<3000 lbs. capacity)

Upright MFH	Order Code	Actual Lift	Down Height	Free Lift	Rack Height (Assumes 10" Lift Off)	Nominal Capacity at Full Height*
<b>ECX 30 / C30C</b>						
226	23-226	154	97.6	56.3	144	3000
226	23-226	166	97.6	56.3	156	2800
226	23-226	178	97.6	56.3	168	2500
226	23-226	190	97.6	56.3	180	2200
226	23-226	201	97.6	56.3	192	2000
251	23-251	226	108.0	66.7	216	2000
288	23-288	263	125.0	83.7	253	1500
300	23-300	278	129.5	88.2	268	1500

\*Indicated capacities are for the THG3-4848 attachment at 24" load center.

\*\*Dimensions to fork face assume a 1 3/4" x 4" x 42" Class II fork. \*\*\*Drawings not exact to scale.

For exact capacity contact your local CLARK authorized dealer for an application survey.

## ANSI/ITSDF and Insurance Classification

Standard truck meets all applicable mandatory requirements of Part III-ANSI/ITSDF B56.1 Safety Standard for Powered Industrial Trucks (latest edition at time of manufacture) and Underwriters Laboratories requirements as to fire and electrical shock hazard only for "E" classification. For further information contact a Clark representative.

Users should be aware of, and adhere to, applicable codes and regulations regarding operator training, use, operation and maintenance of powered industrial trucks, including:

- ANSI/ITSDF B56.1
- NFPA 505, fire safety standard for powered industrial trucks - type designations, areas of use, maintenance and operation.
- Occupational Safety and Health Administration (OSHA) regulations that may apply.

Contact your authorized CLARK forklift truck dealer for further information including operator training programs and auxiliary visual and audible warning systems, fire extinguishers, etc., as available for specific user applications and requirements.

Specifications, equipment, technical data, photos and illustrations are based on information at time of printing and are subject to change without notice. Some products may be shown with optional equipment.

## Don't Forget... Safety Starts With You!

### Before operating a lift truck, an operator must:

- Be trained and authorized
- Read and understand operator's manual
- Not operate a faulty lift truck
- Not repair a lift truck unless trained and authorized
- Have the overhead guard and load backrest extension in place
- Perform daily inspections

### During operation, a lift truck operator must:

- Wear a seat belt
- Keep feet, legs and all parts of body inside operator compartment
- Never carry passengers or lift people
- Keep truck away from people and obstructions
- Travel with lift mechanism as low as possible and tilted back
- Allow safe stopping distance and come to a complete stop before leaving operator compartment

### To park a lift truck, an operator must:

- Completely lower forks or attachments
- Move directional lever to neutral
- Apply parking brake
- Turn key off

## ECX30/C30C TURRET TRUCK

Printed in USA MP08125M

© 2012 CLARK Material Handling Company

### FORWARD POSITION \*\*\*

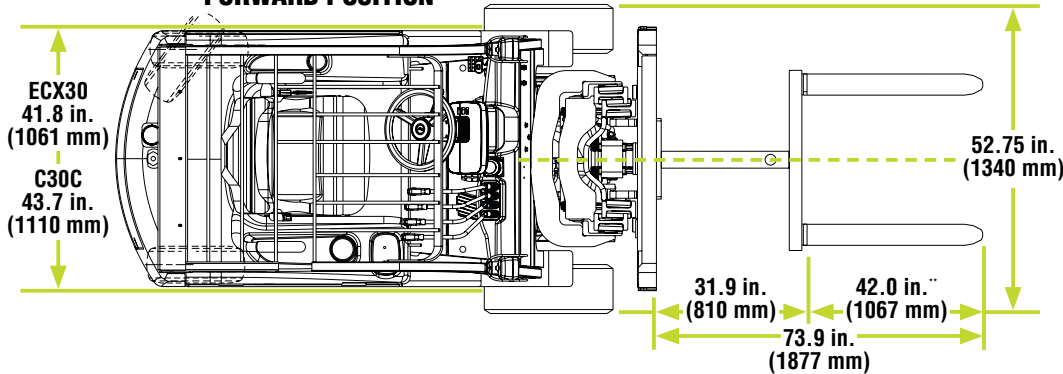

### NESTED IN CARRYING POSITION FULLY SHIFTED LEFT \*\*\*

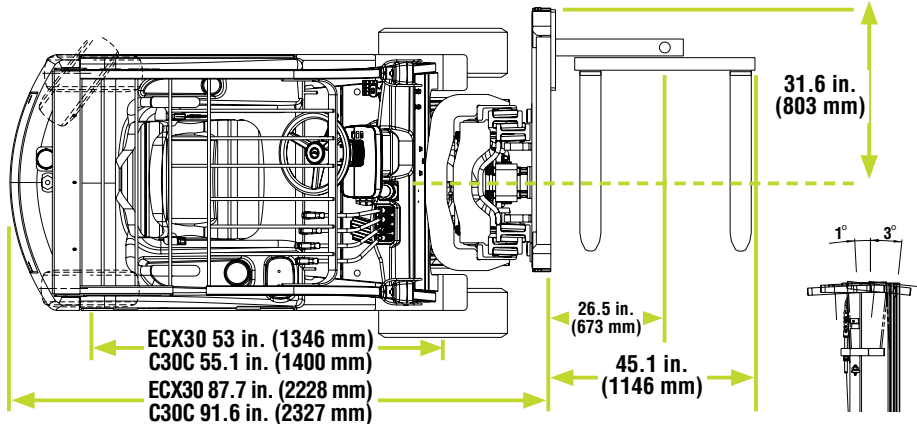

### FULL SIDE SHIFTED STORAGE & RETRIEVING POSITION \*\*\*

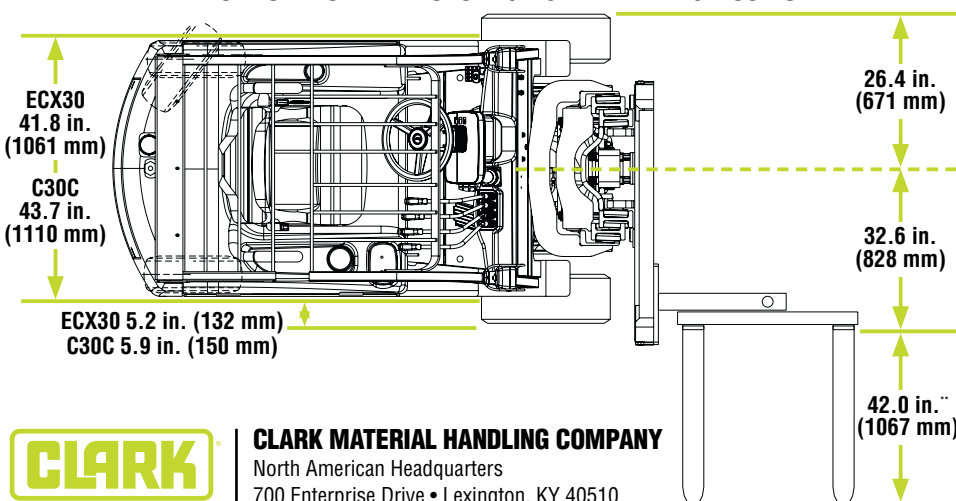

## CLARK MATERIAL HANDLING COMPANY

North American Headquarters  
700 Enterprise Drive • Lexington, KY 40510  
866-252-5275 • [www.clarkmhc.com](http://www.clarkmhc.com)